

ELECTROMECHANICAL LOCK

Promix-SM102

OPERATING MANUAL

Technical description. Installation manual. Certificate.

ПШБА.304268.104 PЭ

PATENT FOR INVENTION

No.2382861

1. PURPOSE

Electromechanical locks series Promix-SM102 with a ball locking mechanism (below called the locks) are intended for restriction of access to trade and office furniture, refrigerator cabinets, chests, various cases and other equipment, which can be opened remotely by energizing/de-energizing (depending on the version) the lock with DC supply voltage by means of switches (buttons) or controllers of access monitoring and control systems, audio and video intercoms, code panels or other devices.

2. LABELING

The label stuck to the lock body contains the following information:

1. Lock model.
2. Patent number.
3. Nominal supply voltage.
4. Nominal consumed current.
5. Date of manufacture and QCD mark
6. Identification number.
7. Manufacturer's website.



An example of information layout on the label.

Promix-SM102.XX.X

Availability of built-in sensors:

0(Absence) - no sensors. 1 - door and lock sensors

Supply voltage:

0 - 12V. 1 -24V

Version:

0 - normally opened, 1 - normally closed

For the list of lock modifications that can be ordered, see 5.2.

The color of the product is shown on the sticker stuck to the box, after the product name. Series colors: **Silver, White, Brown, Black, Gold**

Other colors are provided optionally.

3. SET OF DELIVERY

1 – Lock	1 pc.
2 – Lock fastening plate	1 pc.
3 – Latch, assembled, on the adjustment plate	1 pc.
4 – Angular bracket for latch fastening	1 pc.
5 – Self-tapping screw 3.5x15 (cup head)	6 pcs.
6 – Screw 3x4 (countersunk)	2 pcs.
7 – Marking tool	1 pc.
8 – Operating manual	1 pc.

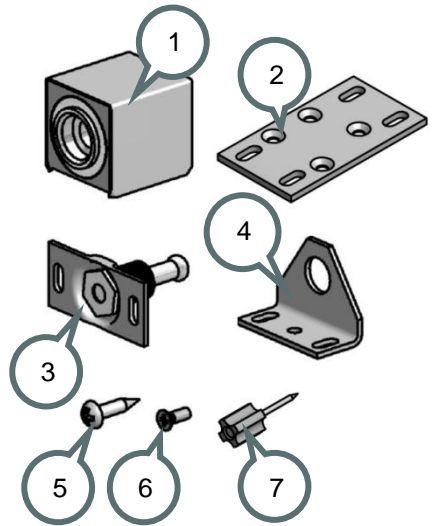

Check completeness of the lock set when buying! After buying, the manufacturer will not accept claims related to incomplete set.

4. DESIGN AND PRINCIPLE OF OPERATION

The locks are produced in two versions: normally opened (NO), and normally closed (NC). NO lock is in the open state when de-energized and in the closed state when the latch is inserted and voltage is supplied. NC lock is in the closed state when the latch is inserted and no voltage is supplied, and in the open state when the lock is energized. For opening the door, it is necessary first to de-energize a normally open lock or to supply voltage to a normally closed lock; only after that the door can be opened.

Depending on modification, NO lock may be provided with a door position sensor. The built-in door position sensor consists of a magnetically controlled sensor (sealed-contact reed relay) mounted on the lock body, and a magnet mounted on the mobile sleeve of the lock and displaced by the latch. The reed relay contacts open when the door is opened (the latch is withdrawn from the lock) and close when the door is closed (the latch is inserted into the lock to a stop). The sensor is located on the rear side of the lock and is fastened by means of a plate.

Do not screw out the plate fastening screws to avoid the sensor operability disturbance!

5. TECHNICAL DATA

5.1 OPERATING CONDITIONS

The lock operation environment must be explosion-safe, free of current-conducting dust or gases that cause metal corrosion and destroying insulation of current conductors and electric elements, free of current-carrying dust or water vapor, and preventing ingress of water, steam, fuel and lubricants.

Climatic conditions of operation – Y3.1 as per GOST 15150-69 with extended temperature range:

- ambient temperature: from -30 to +50 °C;
- Relative air humidity: not higher than 98% at 25°C or lower temperatures without moisture

- condensation and hoar-frost formation;
- installation indoors or outdoors excluding ingress of moisture, dust, dirt, etc. inside the lock.

5.2 TECHNICAL DATA

Modification	Promix-SM102.00	Promix-SM102.00.1	Promix-SM102.01.1	Promix-SM102.01
Version	normally opened			
DC supply voltage U, V	12±2		24±2	
Current consumed, A	0,1 (at 12V)		0,05 (at 24V)	
Operating mode	continuous			
Built-in sensors	-	door position sensor		-
Maximum switch current of the sensor (DC), A:	-	0,5		-
Maximum switch voltage of the sensor (DC), V:	-	36		-
Sensor output signal type	-	"dry contact"		-
Lock weight (not more than), kg	0,17			
Holding force (not less than), kg	150			
Power wire length, m	0,3			

Modification	Promix-SM102.10	Promix-SM102.10-01	Promix-SM102.11-01	Promix-SM102.11
Version	normally closed			
DC supply voltage U, V	12±2		24±2	
Current consumed, A	0,1 (at 12V)		0,05 (at 24V)	
Operating mode	continuous			
Emergency exit	-	emergency exit rod		-
Lock weight (not more than), kg	0,17			
Holding force (not less than), kg	150			
Power wire length, m	0,3			

Lock and latch overall and mounting dimensions.

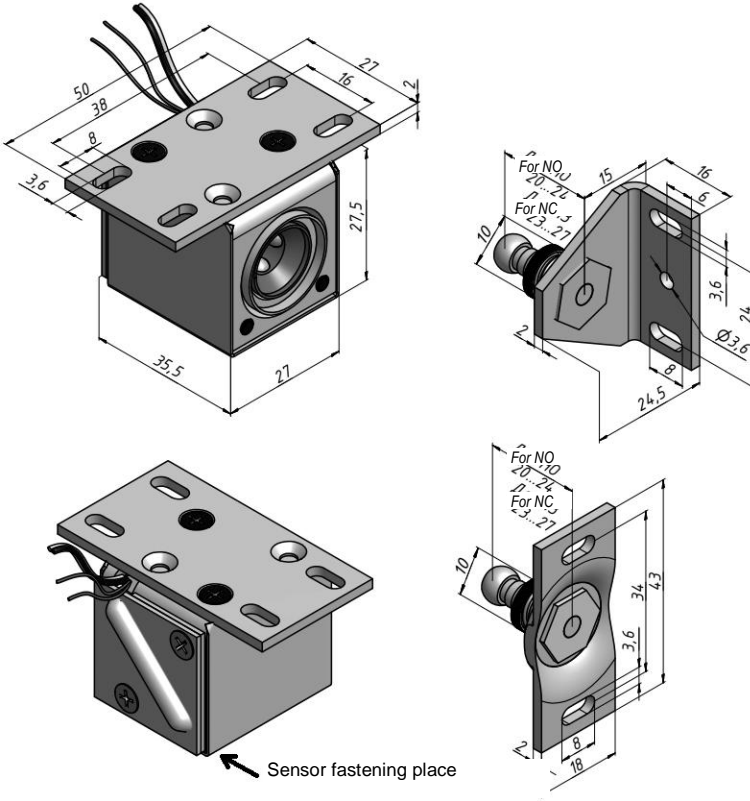

6. INSTALLATION AND CONNECTION

6.1 LOCK MOUNTING

The lock design assumes different versions of mounting the adjustment plate on the lock body. For swing doors and pullout drawers, it is recommended to use positions **1** and **2**. For modifications with a built-in door position sensor, only positions **1** and **2** are possible. For sliding doors of the rolling door cabinet type, it is advisable to use positions **3** and **4**. The plate is fastened to the body by two screws **6**.

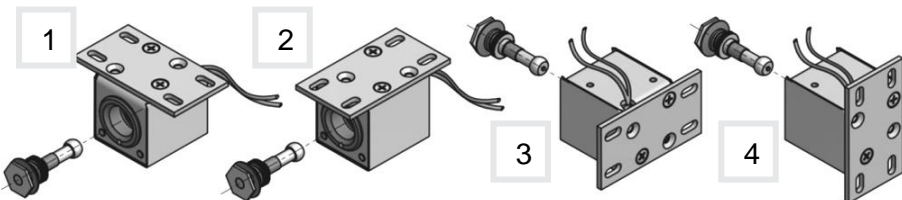

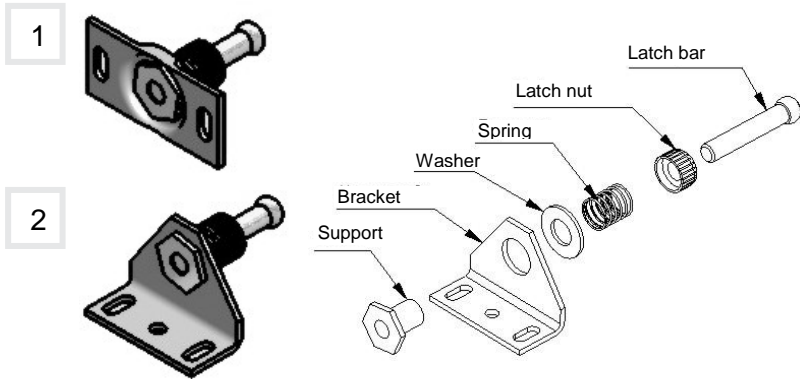

The latch is delivered in an assembled condition **1**, and is suitable for mounting on swing doors and drawers. For sliding doors of the rolling door cabinet type, it is advisable to use the position **2**. Mounting of the latch on the angular bracket is performed by the consumer in accordance with the above-presented diagram.

Example of the lock mounting on a drawer.

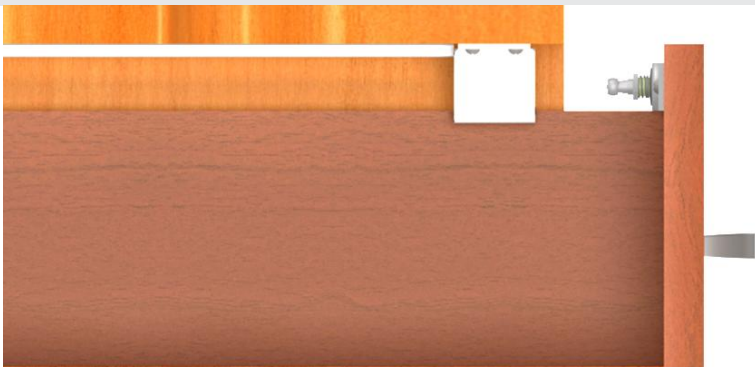
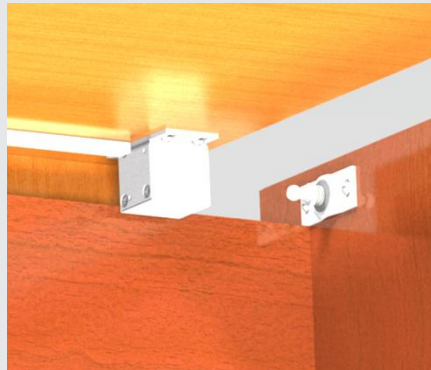
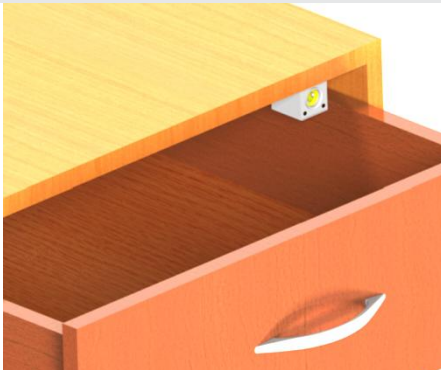

Example of the lock mounting on a swing door.



Example of the lock mounting on a sliding door (rolling door cabinet).



Lock mounting on a swing (sliding) door.

1

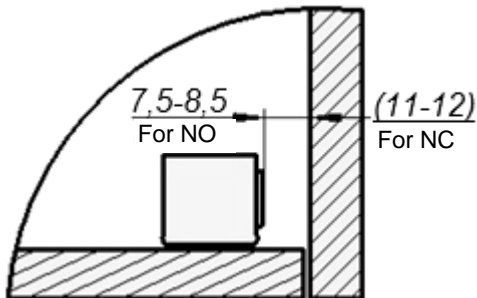

1. Mount the lock on an immobile surface.
2. The distance from the inner surface of the closed door to the lock body must be 7.5-8.5mm for a NO lock or 11-12mm for a NC lock, which guarantees the necessary free movement (play) of the door with the lock closed.

2

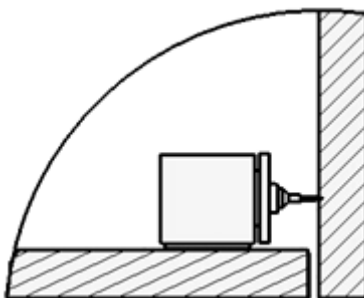

3. Insert the marking tool 7 in the aperture of the lock 1.
4. Close the door and press on it.
5. Cut out the marking template (see below).
6. Pin the marking template on the mark obtained and mark the fastening holes.

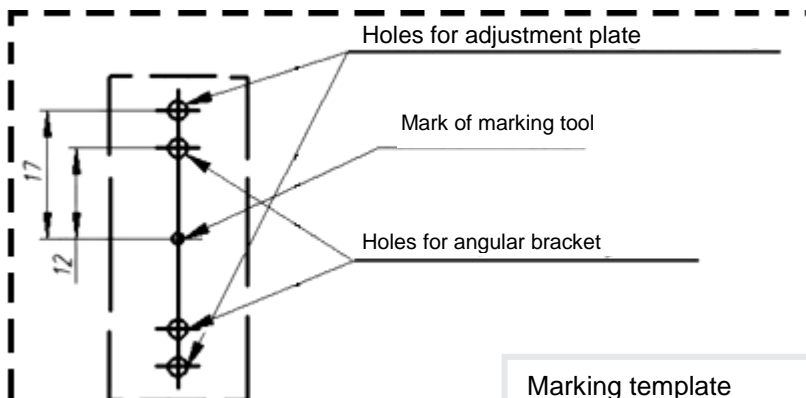

Marking template

Lock mounting on a sliding door of a rolling door cabinet.

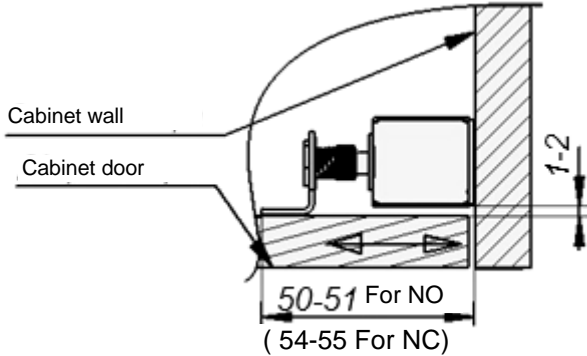

1. Mount the lock on an immobile surface.
2. Fix the lock on the cabinet wall (as shown in Fig.). For a NO lock, make a mark on the door at a distance of 45 mm (49 mm for NC) from the cabinet wall along the lock axis. Pin the marking template on the mark obtained (see p. 7) and mark the fastening holes.
3. Assemble the latch on the angular bracket in accordance with the Fig. (see p. 5) and fasten it to the door.
4. Adjust the latch position so that the distance from the bracket edge to the cabinet wall is 50-51mm for a NO lock (54-55mm for NC).

6.2 CONNECTING PROCEDURE

The lock operation is controlled by means of energizing and de-energizing. For this purpose, a controller (control board) or a switch (button) is generally used. The controller is mounted in accordance with its certificate.

Connect the lock power wires adhering to the following polarity:

- Red (black with a red stripe) – positive pole of the power supply;**
- Black – negative pole of the power supply;**

Application of voltage of reverse polarity does not provide the lock operability but does cause its failure.

See operating voltage range in 5.2. Avoid supply of overvoltage.

Connect sensor leads:

- Colored wires (yellow, green, etc.) – door position sensor output.**

Example of the lock connection to the remote control system Promix-RDS.

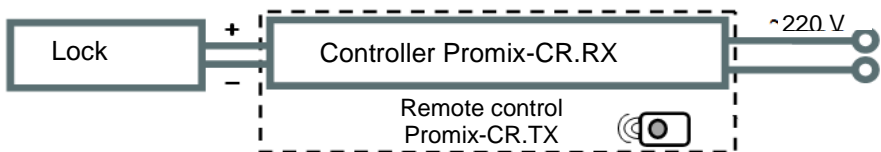

Provide a reliable electric contact. To prevent short-circuit, insulate places of connection.

7. SPECIAL ASPECTS OF INSTALLATION AND OPERATION

- 1) The possibility of using of the locks for restriction of access to the premises and the place of installation (outdoors or indoors) are determined by the **installation organization** on the basis of the design features and the mounting method, room criticality level, the purpose of the access restriction regime and other factors (the presence of security providers, video surveillance, etc.).
- 2) When mounting the lock and the latch, it is necessary to ensure their coaxial alignment within the latch free movement allowance.
- 3) When the door is closed, the latch must be inserted in the lock **to stop**. The lock does not open when the door is in a “tension” condition, i.e., when some external force is applied to open the door, e.g., someone pulls the door handle.
- 4) The properly mounted lock provides the necessary free motion (play) of the door of 2.5-3 mm. If the free play is less, NC lock may **fail to open** when energized, and NO lock may **fail to close** when energized (see section 8).
- 5) Operation of an installed NC lock should be tested only if the supply voltage can be applied thereto.

In all lock fastening versions, the latch bar length must not exceed 24 mm for NO lock and 27 mm for NC lock. The latch length adjustment is performed as follows: fix the latch support with a wrench, loosen the latch nut, screw in/out the latch bar to the required length, rotate the latch nut to a stop, and tighten reliably.

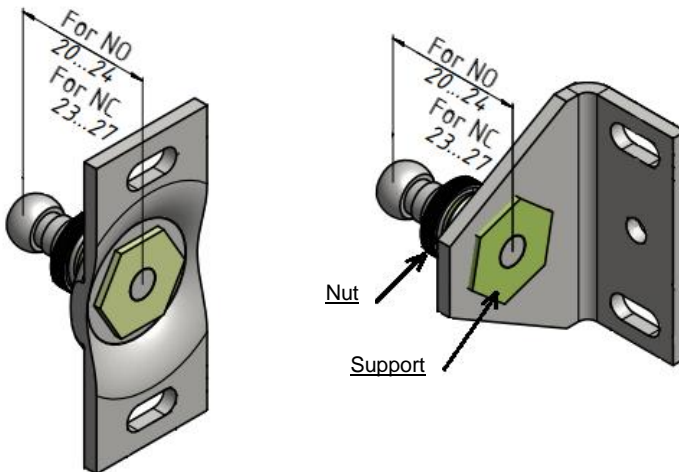

8. TROUBLE-SHOOTING

Troubles and problems	Remedies
<p>Normally closed lock does not open when supply voltage is applied.</p>	<p>Using a tester, check integrity of the lock power circuit.</p> <p>Close the door, case, etc. tightly and press on it at the latch fastening place, and apply voltage to the lock. If the lock does not open, apply an elevated voltage of 20-30 V (up to 36 V for a 24 V modification) for a short time.</p> <p>After the lock opening, increase the latch bar length. To do this, fix the latch support with a wrench, loosen the latch nut, screw out the latch bar, tighten the latch nut.</p>
<p>Increased free play of the latch (more than 3 mm) while the lock is in the closed state.</p> <p>A large clearance between the door and the base as the door is closed (the latch stops against the inside of the lock).</p>	<p>Decrease the latch bar length. To do this, fix the latch support with a wrench, loosen the latch nut, screw in the bar, tighten the latch nut.</p>
<p>The lock does not fix the latch (the door is not closed).</p>	<p>Check polarity and conformity of the lock supply voltage to the required one.</p> <p>Check the distance between the latch and the lock; if necessary, increase the latch bar length. To do this, fix the latch support with a wrench, loosen the latch nut, screw out the bar, tighten the latch nut.</p>
<p>The door is not opened when transferred to the "open" state. To open the door, one has to press it more snugly to the door frame.</p>	<p>Remove the causes of the non-tight door bearing against the door frame.</p> <p>Increase the latch length.</p>
<p>The door has sunk during use (automatic latch alignment is insufficient), therefore, the latch does not enter the lock aperture or hits the lock as enters.</p>	<p>Restore the door position. If this is impossible, remove the latch fixture from the door. Fasten the latch to the door ensuring alignment with the lock aperture.</p>
<p>In a normally opened lock, the latch is not inserted completely into the lock ("balls are seized").</p>	<p>De-energize the lock. Insert a steel rod 3-5 mm in diameter (screw-driver, drill, etc.) into the lock aperture to a positive stop and pull it out.</p>

9. MAINTENANCE

Maintenance of the lock is performed at least once every two months and includes:

- Visual inspection of the lock to check reliability of fastening. If necessary, tighten fasteners of the lock and the latch.
- Check the latch bar length. If the latch bar abuts against the lock body and this leads to gapping between the door and the door base, or if the latch is not fixed when the door is closed, adjust the latch bar length (see section 8).

The lock does not need lubrication!

10. STORAGE AND TRANSPORTATION

Prior to putting into operation, the locks must be stored in the manufacturer's packing, in rooms with an ambient temperature of -30 to +50 °C and a relative humidity not higher than 98% at 25° C in compliance with storage conditions as per GOST 15150-69.

Locks transportation conditions must comply with group C as per GOST 23216-78 in terms of exposure to mechanical factors, and Ж2 as per GOST 15150-69 in terms of exposure to climatic factors.

11. SAFETY REQUIREMENTS

The design of the locks ensures safety of personnel involved in mounting and maintenance.

Due to low DC supply voltage, the products correspond to class III as per ГОСТ 12.2.007.0-75 and are electrically safe.

Fire safety of the locks is ensured by use of non-combustible or hardly combustible materials, and low supply voltage.

12. DISPOSAL

The product is not hazardous for human life and health or for the environment; disposal after its service life is performed without taking any special measures for environment protection.

13. WARRANTY LIABILITIES

The manufacturer, ETC PROMIX LLC, warrants conformity of Promix-SM102 locks to requirements of current Technical Specifications provided that transportation, storage, installation and operation rules established in this Manual are followed.

The warranted operation period is 12 months from the date of sale but not longer than 18 months from the day of acceptance by the manufacturer's QCD.

Within the period of warranty, ETC PROMIX LLC undertakes to repair defective products free of charge. Expenses for transporting the product to the place of repair and back will be borne by the Buyer.

Warranty liabilities do not cover any defects and damages caused by:

- Improper maintenance by the Buyer;
- Use of the product under conditions that do not comply with the operation requirements;
- Mechanical damages or disassembly of the products by the Buyer;
- Non-observance of the transportation and storage rules.

Promix-SM102

Faulty products are accepted for repair only together with the latch, on the obligatory condition that factory labels are retained on the product body.

On expiration of the warranty service period, the manufacturer provides after-warranty service on a contractual basis.

To improve product quality the manufacturing plant reserves the right to make modifications to the product design without prior notice.

14. ACCEPTANCE AND PACKING CERTIFICATE

Electromechanical lock Promix-SM102 in quantity of ____ pieces (1 pc. by default) bearing the manufacturing date and QCD mark on the body, was manufactured and accepted in compliance with Specifications ПШБА.304268.001 ТУ, obligatory requirements of state standards and current technical documentation, recognized as fit for operation and packed by ETC PROMIX LLC.